

CustomCommerce: Selling Complex Products

A CUSTOMER-CENTRIC APPROACH

Customers don't want choices; they want exactly what they want. TechniCon's CustomCommerce allows buyers to quickly find and order complex, highly-configurable products over the Web.

Replicating the expertise of a manufacturer's best salesperson, CustomCommerce-based systems engage users in a dialog, allowing them to specify a range of application-specific constraints for their particular problem.

Customers enjoy an easier, more convenient purchasing experience. You enjoy higher sales and lower costs.

A FLEXIBLE PLATFORM

CustomCommerce provides a flexible platform to support e-commerce solutions for any organization involved with complex products, including manufacturers, resellers and distributors.

To start, CustomCommerce leverages existing product information in almost any format (e.g. text, CSV, HTML, PDF, SIF and CAD files) to get your product data online quickly.

CustomCommerce then enables a comprehensive set of search and selection tools to guide customers through a self-service process, matching products to specific customer needs.

For options and accessories, an industry-leading product configurator applies rules and constraints to ensure that product assemblies are accurate and deliverable.

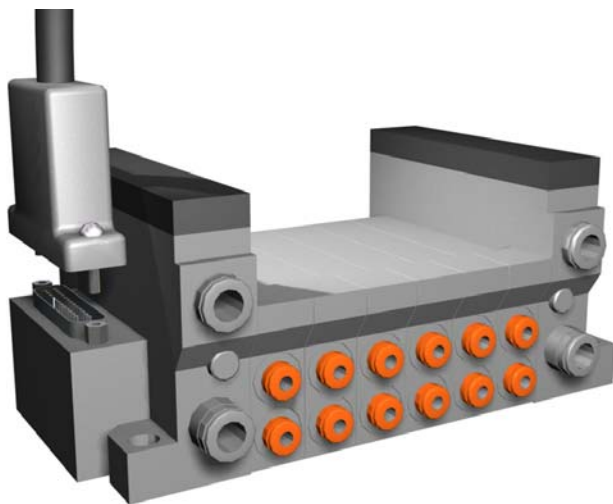

CustomCommerce's selection features combine with advanced product visualization tools to allow customers to see the exact product they've selected.

Customers can rotate and magnify 3D images to examine products from all angles, allowing custom products to be closely reviewed before being ordered.

To document the sales process, CustomCommerce can dynamically generate CAD models, product cut-sheets, bills-of-materials and quotes.

To complete the sale, CustomCommerce offers a full-featured shopping cart and checkout that integrates with existing order-entry systems.

Using CustomCommerce, mechanical engineers no longer have to sort through dozens of printed part catalogs.

Furniture buyers can view different fabrics, finishes and options for a chair without ever visiting a showroom.

The bottom line: faster sales cycles, fewer order errors and returns, more satisfied customers.

TOTAL SYSTEM INTEGRATION

Organizations require platform-neutral solutions that fit into their current computing environment.

With CustomCommerce, you get easy integration with CAD, ERP and e-procurement systems. Your e-commerce system will be available to every office and department in your organization.

CustomCommerce's Web-compliant user interface can be "co-branded" to match your company's existing Web site design and navigation scheme.

PLATFORM REQUIREMENTS

CustomCommerce runs in Windows and Linux environments. Supported Web servers include Apache, IIS and JRun.

No client-side software installation is required. Internet Explorer and Firefox are the recommended Web browsers.

Supported databases include Oracle, SQL Server and open source solutions such as PostgreSQL.

TechniCon's products can be deployed on Java application servers, such as Oracle WebLogic and IBM WebSphere.

KEY FEATURES AND BENEFITS

■ Legacy-to-Web Tools

Using our proprietary tools, existing information such as product descriptions, feature sets and CAD data is automatically extracted and published to the Web. Design data is re-purposed into marketing data.

■ Online Catalogs

CustomCommerce replaces your cumbersome paper catalogs. Using Web-based catalogs, your customers can conveniently select your products anytime and anywhere.

CustomCommerce catalogs are quickly built, easily maintained, support multiple price lists, and allow a complex set of options and accessories to be associated with each catalog item.

"CustomCommerce represents a breakthrough in using the Internet to distribute information about industrial components. In terms of simplicity and ease-of-use, CustomCommerce sets a new bar."

- CAD/CAM Publishing

■ Product Selection and Configuration

Our product selection tools, including parametric search and industry-specific wizards, eliminate the guesswork for your customers, allowing them to quickly locate the right product even if you offer thousands of products with a million variations.

Our product configurator allows users to easily assemble valid products while flagging any incompatibilities. Context-appropriate help messages and cross and up-selling suggestions assist the user.

■ Accurate CAD Models and Drawings

CustomCommerce generates CAD models using the options and dimensions specified in the product selection process. Your customers can download files in a range of CAD formats. Assembly and orientation drawings, along with bills-of-materials, can also be produced.



■ Three-D Product Views

Our interactive 3D visualization tools offer the most effective way to present highly configurable products over the Web. Realistic views of a product's options and features allow your customers to accurately see what they're purchasing, reducing order errors.

■ Reduced Cost-Per-Sale

Your customers can view every product and variation you offer on the Web, allowing them to make educated decisions without the need for expensive repetitive sales calls and back-and-forth design cycles.

■ Faster Sales Cycle

In the past, product selection could take hours or days. CustomCommerce lets your customers choose the right products within minutes, and enhances your sales staff's ability to make timely and accurate quotes.

■ Increased Customer Loyalty

CustomCommerce has a simple yet powerful formula: allow customers to choose products easily, quickly and accurately, and they'll come back again and again.

■ A Single Source for Your E-Commerce Needs

TechniCon provides everything your organization needs for a successful e-commerce initiative: industry-leading software, content development, Web site hosting, system integration, support and training.

CustomCommerce seamlessly integrates with our ContentStudio product. ContentStudio provides a full-featured, Web-based system for managing content in your online catalogs.

These two applications work in tandem to expedite system deployments and ensure long-term ease-of-maintenance.

ABOUT TECHNICON

Founded in 1987, TechniCon is a leading provider of e-commerce solutions for complex products.

TechniCon has developed interactive sales systems for a wide range of manufacturers in the industrial components, lighting, electronics, building products and contract furniture industries.

FOR MORE INFORMATION

155 Doyle Street, Oakland, CA 94607 | 510-653-9163
info@technicon.com | www.technicon.com

©2011 TechniCon Systems, Inc. All rights reserved.